

**AME-3230
AME-3230B
AME-3230W
MOBILE PRINTERS
USER'S MANUAL**



Aug. 02, 2011
Revision 7.0

ARGOX
Empower the Barcode

Website: <http://www.argo.com>

Address: 7F, No. 126, Lane 235, Pao-Chiao Rd., Hsin Tien,
Taipei, Taiwan, R.O.C.

Table of Contents

Proprietary Statement	4
Safety	6
Getting Started	7
Unpacking Printer	7
Package Contents	8
Printer Overview	9
Battery	10
Installing the Battery	10
Charging the Battery	12
Battery & Power Notifications	13
Loading Media	15
Wearing Belt Strap	18
Controls & Connections	24
Self-Test before Connecting	24
Printer Controls and Indicators	25
Smart Battery Power Management	27
Connecting the Printer	29
Drivers & Software	31
Troubleshooting	32
Printer Status Indications	32
Performing Calibration	33
Printing a Configuration Report	34
Printer Maintenance	37
Print Head Maintenance Guide	37
Cleaning the Media Sensor	38
Specifications	39
General Specifications	39

Interface Specifications.....	43
Serial Interface:	43
USB Interface:	44
Bluetooth Interface:	44
IrDA (Infrared) Interface:.....	45
WiFi (802.11 b/g) Interface:.....	45

Proprietary Statement

This manual contains proprietary information of Argox Information Co., Ltd. It is intended solely for the information and use of parties operating and maintaining the equipment described herein. Such proprietary information may not be used, reproduced, or disclosed to any other parties for any other purpose without the expressed written permission of Argox Information Co., Ltd.

Product Improvements

Continuous improvement of products is a policy of Argox Information Co., Ltd. All specifications and signs are subject to change without notice.

FCC Compliance Statement

This equipment has been tested and found to comply with the limits for a Class A digital device, pursuant to Part 15 of the FCC Rules. These limits are designed to provide reasonable protection against harmful interference in a residential installation. This equipment generates, uses, and can radiate radio frequency energy and, if not installed and used in accordance with the instructions, may cause harmful interference to radio communications. However, there is no guarantee that the interference will not occur in a particular installation. If this equipment does cause harmful interference to radio or television reception, which can be determined by turning the equipment off and on, the user is encouraged to try to correct the interference by the following measures:

- Reorient or relocate the receiving antenna.
- Increase the separation between the equipment and the receiver.
- Connect the equipment into a different outlet on a different circuit.
- Consult the dealer or an experienced Radio/TV technician for help.

This unit was tested with shielded cables on the peripheral devices. Shielded cables must be used with the unit to insure compliance. The user is cautioned that any changes or modifications not expressly approved by Argox Information Co., Ltd. could void the user's authority to operate the equipment.

Liability Disclaimer

Argox Information Co., Ltd. takes steps to assure that the company's published engineering specifications and manuals are correct; however, errors do occur. Argox Information Co., Ltd. reserves the right to correct any such errors and disclaims any resulting liability. In no event shall Argox Information Co., Ltd. or anyone else involved in the creation, production, or delivery of the accompanying product (including hardware and software) be liable for any damages whatsoever (including, without limitation, damages for loss of business profits, business interruption, loss of business information, or other pecuniary loss) arising out of the use of or the results of use of or inability to use such product, even if Argox Information Co., Ltd. has been advised of the possibility of such damages.

RF exposure warning

The equipment complies with FCC RF exposure limits set forth for an uncontrolled environment.

The equipment must not be co-located or operated in conjunction with any other antenna or transmitter.

CAUTION:

Any changes or modifications not expressly approved by the party responsible for compliance could void the user's authority to operate the equipment.

Safety

The user is cautioned that any changes or modifications which are not recommended by Argox Information Co. Ltd. could result in the loss of the user's authority to operate the equipment. To ensure compliance, the users must use accessories and peripherals approved by Argox Information Co. Ltd.



Supplemental Information: This device complies with the requirement of FCC Part 15 Rules. Operation is subject to the following two Conditions: (1) This device may not cause harmful interference, and (2) this device must accept any interference received, including interference that may cause undesired operation.



Please only use adapters with the following electrical characteristics and certified by current legislation. Using other adapters may damage the device and void the warranty, and pose risks to the user.

Specifications Input: 100-240VAC, 50-60Hz, 1.0 A
Features Output: 9VDC, 1.56A



The manufacturer declares under sole responsibility that this product conforms to the following standards or other normative documents:

EMC: EN 55022:2006+A1:2007, class A
EN 55024:1998+A1:2001+A2:2003
EN 301489-1/-17
EN 300328



Argox Information Co., Ltd certifies that the following products and/or components are compliant with the current requirements of the European Union Restriction on the use of Hazardous Substances (RoHS) Directive, 2002/95/EC.

Getting Started

Congratulations on choosing AME series mobile printer, made by Argox Information Co., a leader in the worldwide barcode industry. AME series are ideally designed to bring more efficiency to your business. This manual will help you get to know your new printer and provide you with the required information.

Unpacking Printer

After receiving your printer, please check for any shipping damage. Inspect the outside of both the box and the printer for possible damage.

1. Open the top cover of the printer to check that the media compartments are in order.

Note: *If shipping damage is discovered, contact your shipping company immediately to file a claim.*

2. Check whether you have received the following accessories together with the printer. If there are any items missing, please contact your local dealer.



Package Contents

- Printer
- Power Supply
- Battery
- Belt Strap & Screw
- Sample Media
- Media Shield
- CD-ROM
- Print head Cleaning Pen
- Quick Installation Guide

Printer Overview

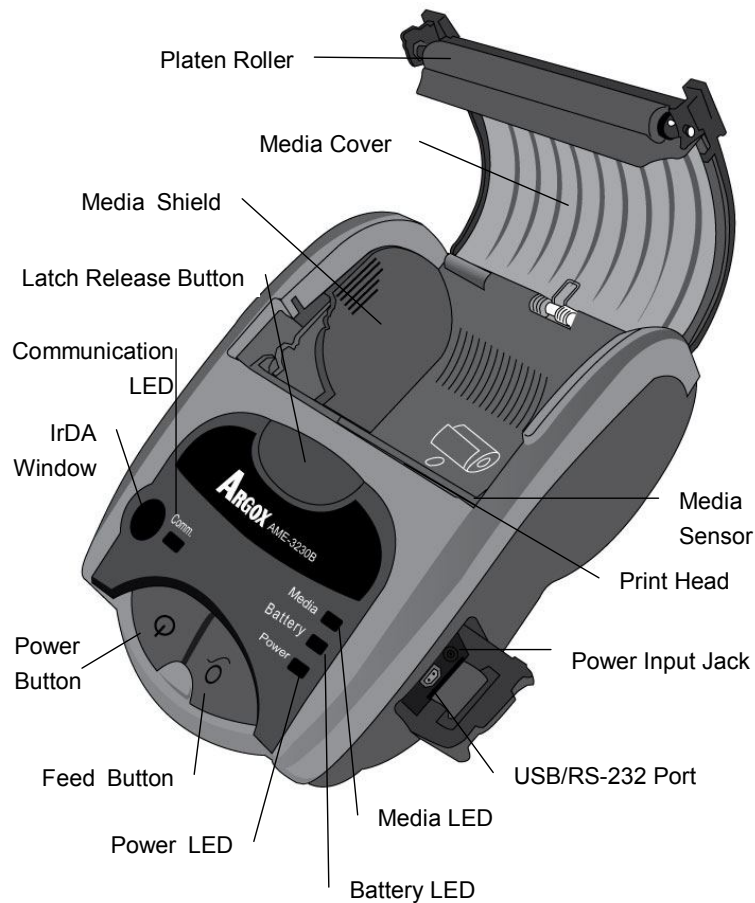

Battery

Each printer package contains one battery pack. The battery must be installed for the printer to work, even if the Power Supply is connected. You must fully charge the battery before using the printer for the first time.

Installing the Battery

1. To release the Battery Cover, rotate the Battery Cover Latch 90° to the right as shown below:

Note: We recommend using a coin to rotate the latch.

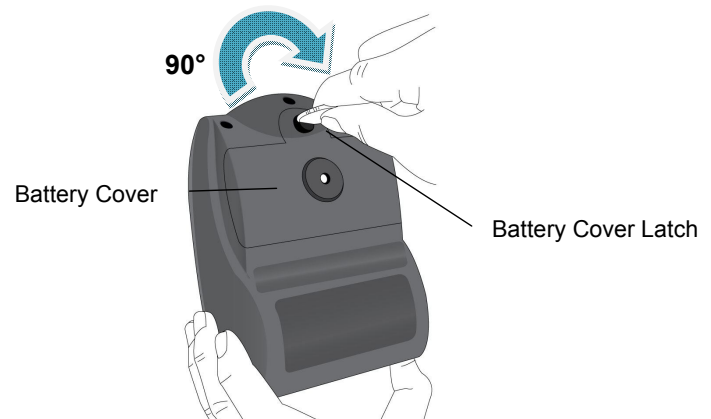

2. Remove the Battery Cover and install the Battery Pack into the

printer:

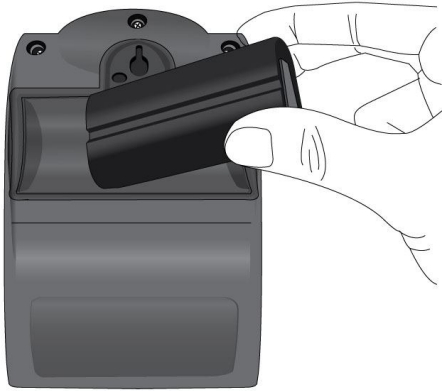

2. Replace the Battery Cover and rotate the Battery Cover Latch 90° to lock in place:

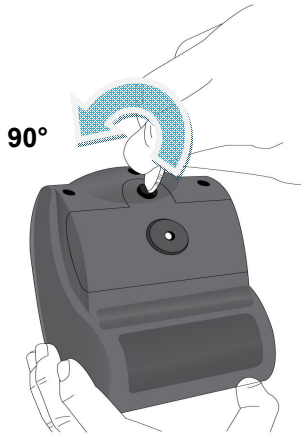

11

AME Series User's Manual

Charging the Battery

1. After installing the Battery Pack, connect the Power Supply into the printer's Power Input Jack.
2. Then plug the Power Supply into the AC wall receptacle. The printer's Battery LED will remain yellow during charging.

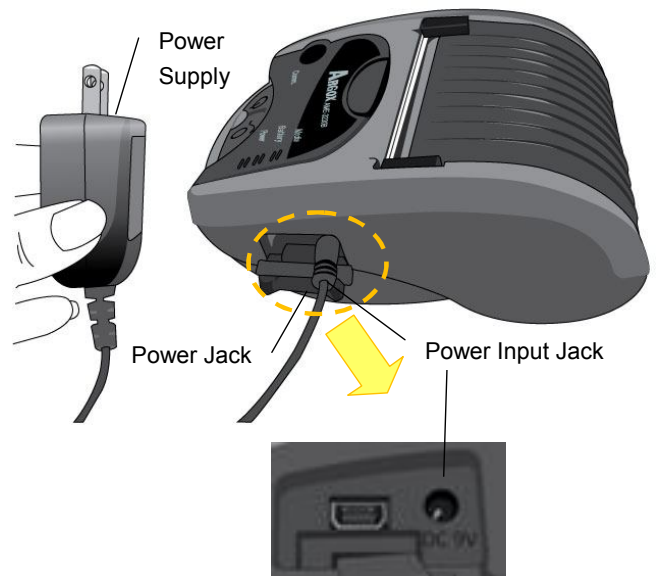

12

AME Series User's Manual

3. The battery is designed for fast-charge; after about **3.5 hours (210 minutes)**, the Battery LED will turn off, signifying that the battery is fully charged and ready for use.

Note: *Operating the printer when charging will increase charging time. Wait until battery is fully charged to operate the printer.*

Battery & Power Notifications

1. Do not disassemble the Battery Pack in case of malfunction.
2. Keep the Battery Pack and printer away from fire, liquids, and conductive material, for your own safety and to avoid possible damage.
3. Be sure only to use the Power Supply and Battery Pack provided or approved by Argox.
4. Any damage caused by abnormal use will void the warranty.
5. When the battery not used in long-term, maintained of power at 50% and stored at -20 ~ 25 ° C.

Loading Media

1. Press the Latch Release Button on printer to automatically open the Media Cover:

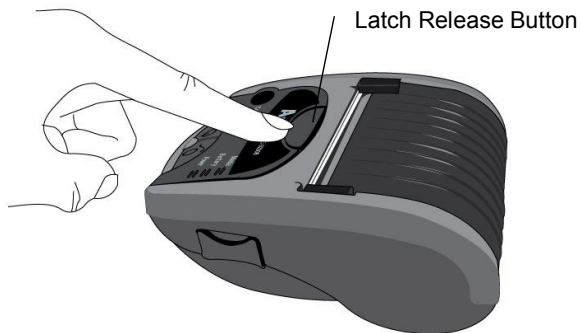

2. Place the media supply roll into the Media Compartment. Make sure media supply unwinds near Print Head, as in the direction shown below:

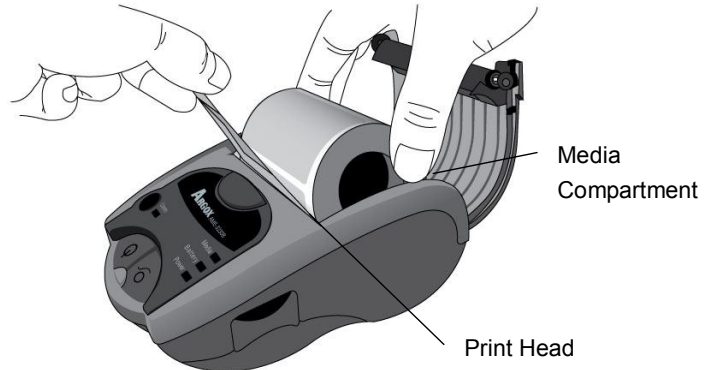

3. For media supply rolls with width less than 3 inches:
Load media supply first, and then align media supply roll to the right end for correct detection of Media Sensor:

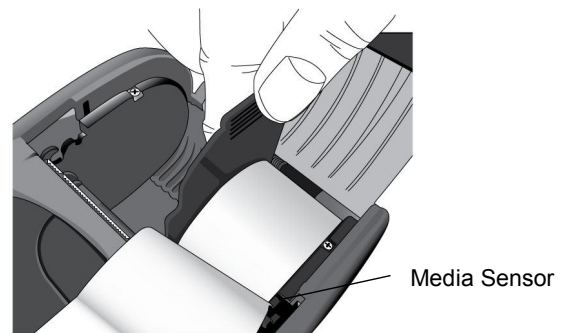

4. Install the Media Shield into Media Compartment, and lean closely against the media supply roll:

15

AME Series User's Manual

16

AME Series User's Manual

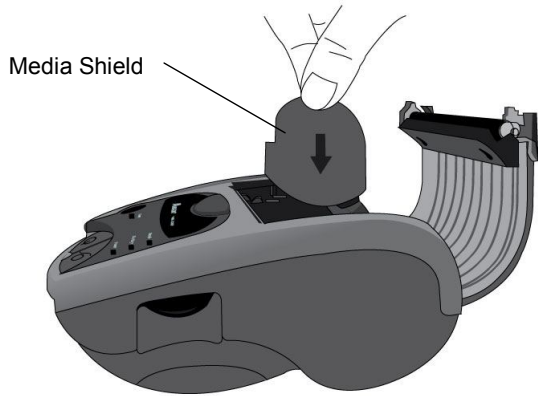

5. Pull a short length of media out of the printer. Close the Media Cover and press until you hear a click, to properly latch:

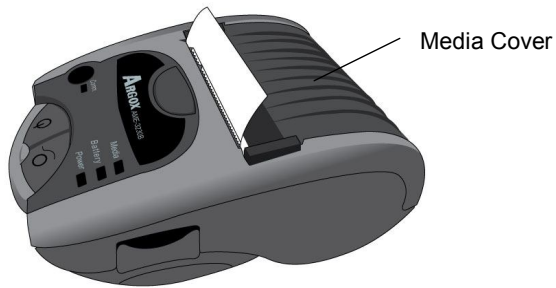

6. Tearing Media:

To tear media, pull the media edge against the Tear Bar as in the direction below:



Wearing Belt Strap

The convenient Belt Strap design, a standard feature of Argox AME series, is easy to use and quick to install:

1. Prepare the Belt Strap and the Screw.
Locate the Knob on the underside of the printer, right above the Battery Cover:

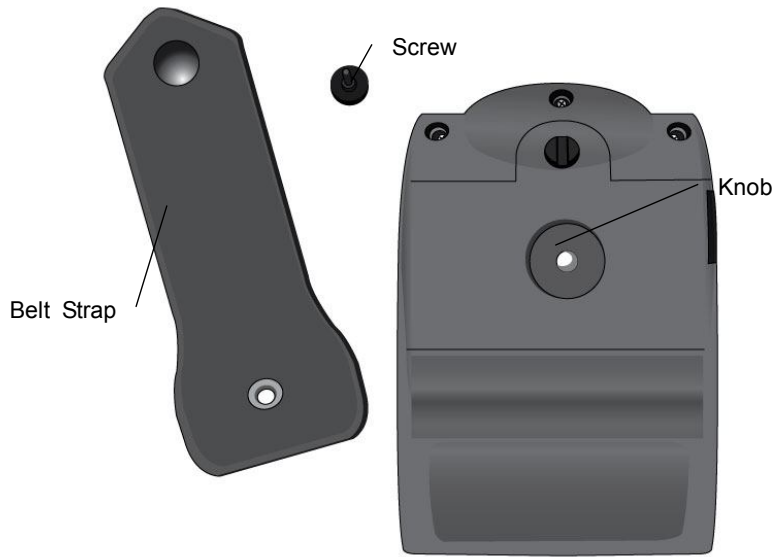

2. Attach the Belt Strap onto the Knob.

Note that the exterior surface of the Belt Strap should face toward you:

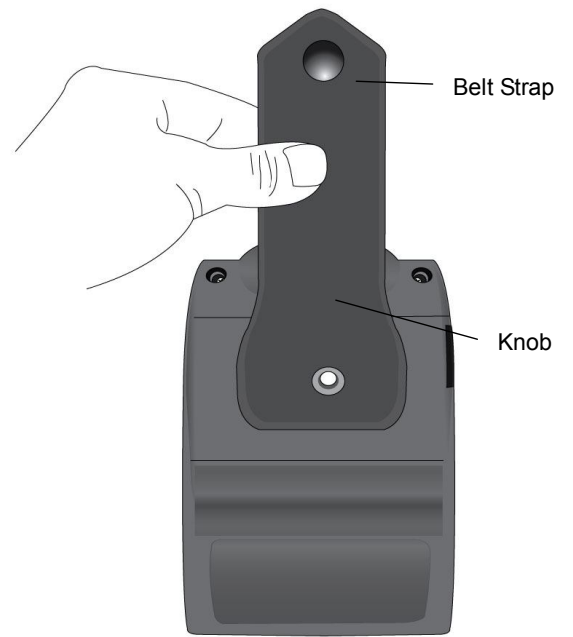

3. Insert the Screw onto the Knob, through the Belt Strap, and tighten clockwise until it is fully secured:

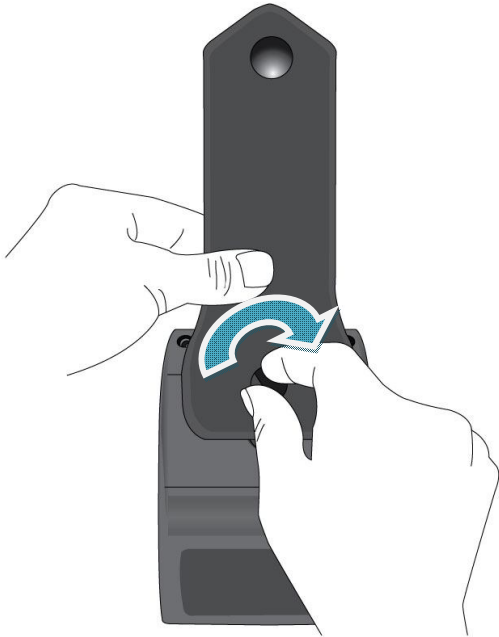

21

AME Series User's Manual

4. With the Belt Strap attached to the printer, place the top of the Belt Strap over your belt:

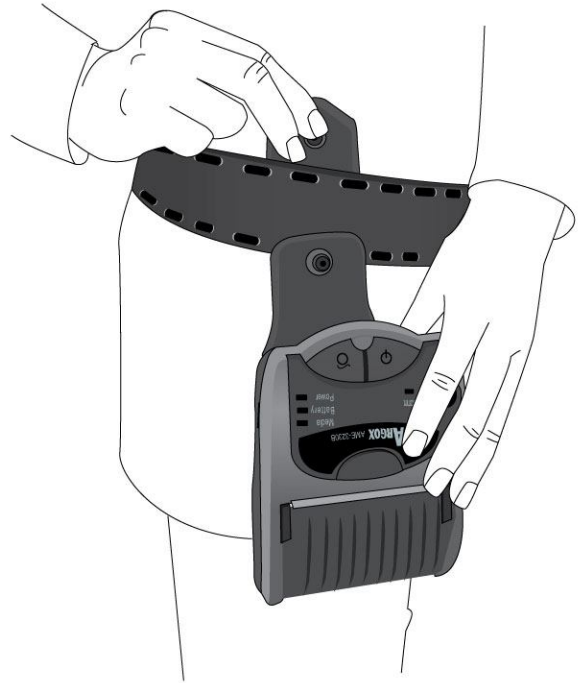

22

AME Series User's Manual

5. Pull down the top of the Belt Strap to fix onto the lock:



Controls & Connections

Self-Test before Connecting

After the Battery is charged and media is loaded, before connecting the printer to a computer or a portable data terminal, perform a printer self-test label to verify that the printer works properly:

Printing a Self-Test Label

- Press the Power Switch to turn off the printer.
- Make sure the Battery is installed, and media is loaded.
- Press and hold the Feed Button, and then press the Power Switch to turn on the printer.
- After printer starts to print, release the Feed Button.
- Wait until printer finishes printing, press the Power Switch or Feed Button to resume normal printing mode.

Note: For more information on self-test printouts, see Page 30. Troubleshooting – Printing a Configuration Report

Printer Controls and Indicators

The printer's controls and indicators are shown in the diagram below:



Feed Button:

1. Pressing this button during printing will make printer pause.
2. To feed a blank label.

Power Button: Turn the printer ON/OFF.

The following table explains control and indicator functions to help understand LED indications and printer status:

Printer Status	Power LED (Green)	Battery LED (Yellow & Red)	Media LED (Orange)	Communication LED (Blue)	Beep
Power On	ON				
Power Off					
Media Out	ON		Blinking		Beep
Bluetooth or 802.11b/g Connection	ON			ON	Beep x1
IrDA Connection	ON				Beep x2
RS232 Connection	ON				Beep x3
Charger Connected		ON (Yellow)			
Battery Low	ON	Blinking slowly (Red)			
Battery Out (printer will power off)	ON	Blinking fast (Red)			Beep

Smart Battery Power Management

The AME series mobile printers are equipped with a Li-ion battery pack (7.4V 2200mAh). With the Smart Battery Power Management function, AME series are able to monitor and automatically remind operators of different battery power status:

Battery Power Status	Printer's Indications
Charging Mode	Battery Green LED remains On (Charging Mode) If Battery is fully charged, LED will be off.
10%	Battery LED blinks slowly (Reminder: battery power will be 5% in about 30-60 minutes)
5%	Battery LED blinks + warning beeps (Reminder: battery power will be 0% in about 30-60 minutes)
0%	Printer suspends printing (some minor power remains)

Note:

1. *If the standby duration exceeds 3 minutes, printer will turn off automatically in order to decrease power consumption.*
2. *The standby duration is changeable, to be set by operators; printer's default standby duration is 3 minutes.*

Connecting the Printer

The interfaces of AME-3230 include RS-232, USB (2.0), and IrDA.

The interfaces of AME-3230B include RS-232, USB (2.0), IrDA, and Bluetooth 2.0.

The interfaces of AME-3230W include RS-232, USB(2.0), IrDA and 802.11b/g.

USB and RS-232 communication cables are optional accessories.

USB & RS-232 Communications:

No additional setups are required for cable communications.

Note: Turn off the printer before connecting or disconnecting USB or RS-232 interface cables

- **USB:**

Once USB cable is connected, printer will detect automatically and link to host, without emitting beeps.

- **RS-232:**

When printer is off and RS-232 cable is connected, printer will emit 3 beeps and automatically switch to RS-232 mode. Next time printer is turned on with RS-232 cable connected, printer will emit 1 beep (Bluetooth mode), and then 3 beeps to indicate RS-232 mode.

When RS-232 cable is disconnected, printer will emit 1 beep and switch back to Bluetooth mode.

Bluetooth, 802.11b/g and IrDA

Communications:

The default communication mode of AME-3230B is Bluetooth and AME-3230W is 802.11b/g. Following is an explanation of how to switch between Bluetooth, 802.11b/g and IrDA modes.

- **IrDA:**

- a. How do I switch to IrDA mode from Bluetooth mode?
When the printer is in Bluetooth mode, press and hold the Feed Button for 5 seconds until you hear 2 beeps. The printer will then be in IrDA mode.

- b. How do I switch to IrDA mode from 802.11b/g mode?
When the printer is in 802.11b/g mode, press and hold the Feed Button for 5 seconds until you hear 2 beeps. The printer will then be in IrDA mode.

- **Bluetooth or 802.11b/g:**

- a. How do I switch to Bluetooth mode from IrDA mode?
When the printer is in IrDA mode, press and hold the Feed Button until you hear one beep. The printer will then be in Bluetooth mode.

- b. How do I switch to 802.11b/g mode from IrDA mode?
When the printer is in IrDA mode, press and hold the

Feed Button until you hear one beep. The printer will then be in 802.11b/g mode.

As long as the printer is in Bluetooth mode or 802.11b/g mode, the Communication Indicator will remain blue, whether Bluetooth or 802.11b/g connection to host is linked or unlinked.

Note: *The Communication Indicator will blink blue during data transmission via all interfaces – Bluetooth, IrDA, RS-232, 802.11b/g and USB.*

Drivers & Software

AME series are bundled with their smart printer drivers. This way, users can easily print a receipt or label within any Windows applications, e.g. Microsoft Word, labeling software such as Bartender, .etc, in operation systems including Windows 2000/XP/Vista/Windows 7.

The AME series drivers and Bartender labeling software are available via Argox CD-Rom included in the printer package.

Troubleshooting

Normally, when the printer is not working properly, the "Power" LED blinks continuously; while printing and communication between the host and printer stops.

Printer Status Indications

Printer status and error indications are displayed via LED indicators. Generally, when a malfunction or an abnormal condition is detected, the ERROR LED will blink.

The table below shows the LED indications corresponding to various errors:

Status	Blinking LED
PAUSE	POWER LED blinking
Possible Symptoms & Solutions	
The printer is in PAUSE status. Press FEED button to return to normal printing mode.	

Status	Blinking LED
MEDIA OUT	MEDIA LED blinking
Possible Symptoms & Solutions	
<ol style="list-style-type: none"> 1. The media is not installed or is used up. 2. Printer fails to detect the media gaps/black marks. 	

Status	Blinking LED
SERIAL I/O ERROR	POWER LED blinking
Possible Symptoms & Solutions	
The format or baud rate of the RS232 communication is inconsistent between the printer and host.	

Status	Blinking LED
MEMORY FULL	POWER LED blinking
Possible Symptoms & Solutions	
The printer memory buffer is fully loaded with downloadable soft fonts, graphics or forms. Check the format and size of stored data with available memory size or call for service.	

Status	Blinking LED
Print Head overheated	POWER LED blinking
Possible Symptoms & Solutions	
Printer enters PAUSE status to wait for print head to cool down; printer will resume printing tasks when it is ready.	

Performing Calibration

If labels with gaps/black marks are in use, perform media calibration

before printing to make printer index correctly.

1. Properly install labels.
2. Power off the printer.
3. Press and hold the FEED button then turn on power; do not release the button until printer starts to feed labels.
4. Then, press FEED button once or twice to check that labels are correctly indexed.

Note: You must always carry out calibration when changing media. Failure to do so will result in improper detection by the label sensor.

Printing a Configuration Report

The Configuration report, also known as the Self-Test report, can work as a printer diagnosis tool. Steps to print a Configuration report are listed below:

1. Press the Power Button to turn off the printer.
2. Make sure the Battery is installed and media is loaded.
3. Press and hold the Feed Button, and then press the Power Switch to turn on the printer.
4. After printer starts to print, release the Feed Button.
5. Wait until printer finishes printing, then press the Power Switch or Feed Button to resume normal printing mode.

Sample printout of Configuration (Self-Test):

Mobile Printer AME3230-201.00 113009
 STANDARD RAM: 8388600 BYTES
 AVAILABLE RAM: 6605104 BYTES
 LABEL LENGTH: 21 M
 FLASH MEMORY: 4096K BYTES
 INT. FONTS: FONT ID: 966
 CHAR. SET: 136
 HEIGHT: 13
 H. POSITION ADJUST.: 0000
 CHECKSUM: 0000
 LAB LEN(TOP TO TOP): 43 mm.
 ABS. DARKNESS: 16
 TRIM. DARKNESS: 0
 DIRECT THERMAL
 REF: 2099
 MOTOR LEVEL: LOW

 RS232: 9600, 8, N, 1P. XON/XOFF.
 MAX LABEL HEIGHT: 100 INCHES
 CARET CONTROL CHAR : <^> 5EH
 DELIMITER CONTROL CHAR : <,> 2CH
 TILDE CONTROL CHAR : <~> 7EH
 CODE PAGE : USA1
 MEDIA : CONTINUOUS
 REPRINT AFTER ERROR : ENABLED
 SLEEP TIME: 3 MINUTES
 LABEL ANALYSIS LENGTH: 80 mm
 BLUETOOTH DEVICE: Argox AME-3230
 BLUETOOTH PIN: 0000

→ Firmware version
 → Printed label length
 → Flash memory capacity

 → RS-232 parameters
 → Media type setting
 → Standby duration (in minutes)
 → Bluetooth PIN code

THIS IS FONT A. 0123ABCabc
 THIS IS FONT B. 0123ABCabc
 THIS IS FONT C. 0123ABCabc
 THIS IS FONT D. 0123ABCabc
 THIS IS FONT E. 0123ABCabc
 THIS IS FONT F. 0123ABCabc
FONT G. 0123
 THIS IS FONT H. 0123ABC
CG Triumv Bd Condensed.

→ Internal fonts

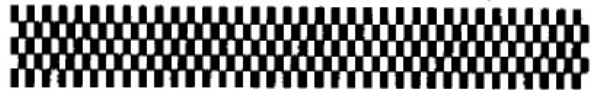

Print Head test

Printer Maintenance

Print Head Maintenance Guide

To keep the Print Head in the best conditions and efficiency and to extend duration for use, regular cleaning action is needed:

Note: Always switch off printer before cleaning.

1. Cleaning Interval:

It is strongly recommended to regularly clean print heads, or at least every time a label roll is changed (in direct thermal printing mode). In addition, if the printer is operated under critical applications or environments, or if print quality is found to have degraded, please clean print heads more frequently.

2. Cleaning Material:

The surface of print head's heating element is very fragile. To prevent from any possible damage, please use the Printhead Cleaning Pen supplied in the printer package, or a soft cloth/ cotton buds with "Ethanol" or "industrial alcohol" to clean print head's surface.

It is strongly recommended to wear gloves during cleaning. Do not touch print head surface with bare hands or with any hard objects.

Water and moisture should be kept away from the print head to avoid corrosion of the heating elements.

3. Cleaning Direction:

When cleaning the print head, always wipe in One Direction - from Left to Right only, or, from Right to Left only, to gently clean the "Heating Line" of the print head without putting excessive stress on the unit.

Do not wipe back and forth to avoid dust or dirt on the cleaning cloth/cotton buds attaching to print head again.

Cleaning the Media Sensor:

Debris or dirt on the Media Sensor can cause a misread or unstable detection to index label gaps/black marks. Clean the Media Sensor properly with a cotton bud dampened with alcohol.

Specifications

General Specifications

Specifications	AME-3230	AME-3230B	AME-3230W
Printing Method	Direct Thermal		
Printing Resolution	203 dpi (8 dots/mm)		
Printing Speed	2~ 3ips (51 ~76mm/s)		
Printing Length	40" (1016mm)		
Printing Width	2.8" (72mm)		
Memory	8MB DRAM (6MB User available), 4MB Flash ROM (3MB User available)		
CPU Type	32 bit RISC microprocessor		
Media Sensor	Media gap/black line sensor, Paper end sensor, Open cover sensor		
Operation Interface	LED indicator x 4 (Power status/Battery/Media/Communication), Button x 2 (Power/Feed)		
Communication Interface	RS-232, USB (2.0), IrDA 39 AME Series User's Manual	RS-232, USB (2.0), IrDA, Bluetooth 2.0	RS-232, USB(2.0), IrDA, Wireless 802.11b/g

Wireless Security Authentication and Encryption Options	N/A	N/A	WEP-128, WPA-PSK (TKIP), WPA2-PSK (AES)
Fonts	Internal character sets standard 5 alpha-numeric fonts from 0.049"H ~ 0.23" H (1.25mm ~ 6.0mm) All fonts are expandable up to 24x24 4 direction 0 ~ 270 rotation Ability to print any Windows True Type font easily with help of the Font Utility provided		
1D Barcodes	Code 39 (standard/with checksum digit), Code 93 Interleaved 2 of 5 (standard/with checksum digit/with human readable check digit), EAN-8, EAN-13, UPC-A, UPC-E, Postnet, Codabar, Code 128 subset A/B/C, Code 128 Auto, UPC/EAN-Extension, Plessey, Industrial 2 of 5 , Standard 2 of 5, Logmars, MSI, Code 11, GS1 DataBar		
2D Barcodes	MaxiCode, PDF417, Data Matrix (ECC 200 only), QR code, Composite codes		
Graphics	GRF, Hex and GDI		

Emulation	PPLZ
Windows compatibility	Win CE.NET, Pocket PC, Windows Mobile, Windows 2000/XP/VISTA/Windows 7
Software	BarTender, Printer Utility, Font Utility
Media Type	Direct Thermal continuous receipt, Direct Thermal labels, die-cut, black mark, Direct Thermal stickers
Media	Max Width: 3" (78.5mm) Min Width:1" (25.4mm) Max roll capacity (OD): 2.2" (57mm) Thickness: Receipt (0.0508~0.1016mm)/Label: Max. 0.15mm
Drop protection	1.5m
Dimensions	W 106mm x H 70mm x L 153mm
Weight	670g (Printer + Battery + 3" width OD 2.2" Paper roll)
Power Source	100-240VAC 50-60 Hz Input;9 VDC 1.56 A output
Battery	Rechargeable 7.4V Lithium-ion, 2200mAh, Operating 8 hours (Cover rate 30%), standby 14 hours
Operation Environment	Operation Temperature: 14°F~122°F (-10°C~50°C), 0% ~ 90% non-condensing** Storage Temperature: -4°F~140°F (-20°C~60°C)
Standard Items	Belt Strap, Battery, AC adapter, Printhead Cleaning Pen, Sample Receipt Paper Roll, Quick Installation Guide, CD-ROM

Optional Items	Shoulder Strap, Environmental Case, Spare Battery, One Battery Charger, 4 Bay Battery Charger, Vehicle Power Adapter, USB/RS-232 Cables
-----------------------	---

**** Special configuration**

Interface Specifications

Serial Interface:

RS-232C port with a mini-type 10-pin connector.

Flow Control mechanism is either RTS/CTS or X-on/X-off (control characters are DC2 and DC4).

Programmable parameters are listed below:

Speed: 1200, 2400, 4800, 9600, 19200,
38400, 57600, 115200 bauds

Parity: Odd, Even or None.

Data Bits: 7 or 8 bits.

Stop Bit(s): 1 or 2 bits.

Factory Default Parameters: 9600 bauds, no parity,
8 data bits, 1 stop bit.

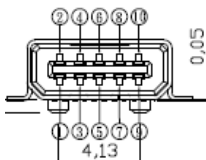

Pin	Signal	Description
3	Transmitted Data, TxD	Output. Serial "Transmitted Data".
5	Received Data, RxD	Input. Serial "Received Data"
7	Request to Send, RTS	Output. Used as the control signal for "H/W Flow Control "
9	Clear to Send, CTS	Input. Used as the control signal for "H/W Flow Control"
10	GND	Signal ground

USB Interface:

This port complies with USB 2.0 Full-Speed communication.

The USB interface is a mini-type USB 10-pin connector.

Pin	Signal	Description
2	VBUS	5V
4	D -	Differential data signaling pair -
6	D +	Differential data signaling pair +
10	GND	Ground

Bluetooth Interface:

Bluetooth version: 2.0

Communication range: 10 meters

IrDA (Infrared) Interface:

IrDA version: 1.0

Communication zone:

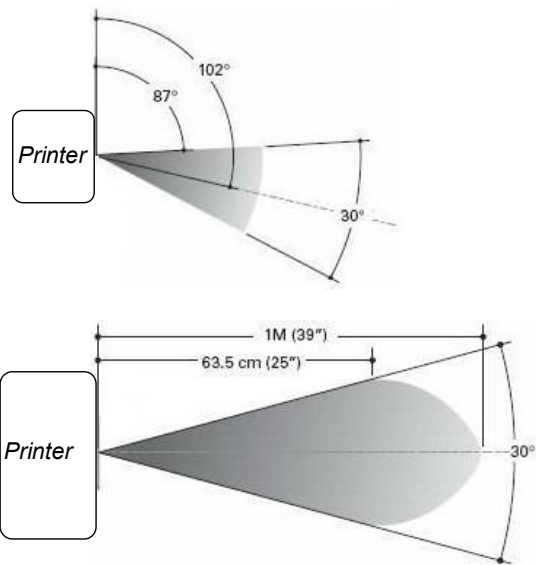

Wi-Fi (802.11 b/g) Interface:

Wireless Security Authentication and Encryption Options:

WEP-128, WPA-PSK (TKIP), WPA2-PSK (AES)

Wireless access modes: Infrastructure and ad-hoc

Network support: DHCP, UDP, DNS, ARP, ICMP, TCP, sockets